



INSTITUT FÜR INFORMATIK

**Sonderforschungsbereich 342:
Methoden und Werkzeuge für die Nutzung
paralleler Rechnerarchitekturen**

Deciding Finiteness of Petri Nets up to Bisimulation

Petr Jančar, Javier Esparza

**TUM-I9541
SFB-Bericht Nr.342/23/95 A
Dezember 1995**

TUM-INFO-12-95-141-50/1.-FI

Alle Rechte vorbehalten
Nachdruck auch auszugsweise verboten

©1995 SFB 342 Methoden und Werkzeuge für
die Nutzung paralleler Architekturen

Anforderungen an: Prof. Dr. A. Bode
Sprecher SFB 342
Institut für Informatik
Technische Universität München
D-80290 München, Germany

Druck: Fakultät für Informatik der
Technischen Universität München

Deciding finiteness of Petri nets up to bisimulation

Petr Jančar

Dept. of Computer Science
University of Ostrava
Dvořákova 7, 701 03 Ostrava
Czech Republic

Javier Esparza

Institut für Informatik
Technische Universität München
Arcisstr. 21, D-80290 München
Germany

Abstract

We study the following problems for strong and weak bisimulation equivalence: given a labelled Petri net and a finite transition system, are they equivalent?; given a labelled Petri net, is it equivalent to some (unspecified) finite transition system? We show that both problems are decidable for strong bisimulation and undecidable for weak bisimulation.

1 Introduction

The decidability of equivalence notions for infinite-state systems has been extensively studied in the last years. Among other results, it has been shown that trace equivalence is undecidable for Basic Process Algebra (BPA) and Basic Parallel Processes (BPP), while bisimulation equivalence is decidable in both cases [1, 2, 4].

For arbitrary labelled Petri nets (called just Petri nets in the rest of this introduction), all the equivalence notions commonly used in the literature are undecidable [9, 7]. Therefore, in order to obtain positive results some constraints have to be imposed on the nets accepted as problem instances.

The case in which one of the two Petri nets to be compared is bounded has been considered in [10, 13]. For interleaving equivalence notions like language, trace or bisimulation equivalence, a bounded Petri net is equivalent to a finite transition system. So, loosely speaking, a Petri net is compared against a regular behaviour. The authors of [10, 13] study the following two problems:

- The *equivalence* problem (EP): given a Petri net and a finite transition system, are they equivalent?
- The *finiteness* problem (FP): given a Petri net, is it equivalent to some (unspecified) finite transition system?

Notice that the versions of EP and FP for deterministic or general context-free grammars and language equivalence are classical results of language theory (see for instance [5], p. 281).

In [13], Valk and Vidal-Naquet showed that EP and FP are undecidable for language equivalence. In the years following the publication of this paper, other equivalences based on the notion of transition system were found to be more appropriate for the verification of concurrent systems; two of the most commonly used today are trace and bisimulation equivalence.¹ In [10], EP and FP were studied again for these two equivalences (as well as for the simulation preorders). EP was shown to be decidable in both cases, while FP was shown to be undecidable for trace equivalence. FP for bisimulation was left open

¹The language of a Petri net is defined as the set of words corresponding to occurrence sequences which lead to some final marking, while its trace set contains the words corresponding to all occurrence sequences.

We show in this paper that FP is decidable for bisimulation. We also show that both EP and FP are undecidable for weak bisimulation. Using these results and some unpublished ones from [8], we can then complete a picture on EP and FP, which is shown in the conclusions.

The paper is structured as follows. Sections 2 and 3 contain some preliminaries. Sections 4 and 5 are devoted to EP and FP for bisimulation, respectively. Sections 6 and 7 study the same problems for weak bisimulation. (Although the decidability of the equivalence problem was already proved in [10], we prove it again in Section 4; the new proof is arguably simpler, and all the lemmas are needed in Section 5 anyway.)

2 Preliminary definitions

Let Act be a finite set of *actions*, containing a distinguished element τ called the *invisible* or *silent* action.

A (*rooted, labelled*) *transition system* over Act consists of a set of states S with a distinguished initial state and a relation $\xrightarrow{a} \subseteq S \times S$ for every action $a \in Act$.

A (*finite, labelled, place/transition Petri*) *net* over Act is a tuple $N = (P, T, W, M_0, \ell)$ where

- P and T are finite and disjoint sets of *places* and *transitions*, respectively;
- $W: (P \times T) \cup (T \times P) \rightarrow \mathbb{N}$ is a *weight function*;
- $M_0: P \rightarrow \mathbb{N}$ is the *initial marking* of N ; and
- $\ell: T \rightarrow Act$ is a *labelling*, which associates an action to each transition.

If $W(x, y) \in \{0, 1\}$ for every x, y then N is called *ordinary*.

We fix some total ordering p_1, p_2, \dots, p_n of the places of P . A marking of N , i.e., a mapping $M: P \rightarrow \mathbb{N}$ attaching $M(p)$ *tokens* to a place p , is also denoted by the vector $(M(p_1), \dots, M(p_n))$.

We define

$$\Delta(t) = (W(t, p_1) - W(p_1, t), \dots, W(t, p_n) - W(p_n, t))$$

for every transition t , and $\Delta(u) = \sum_{i=1}^m \Delta(t_i)$ for a sequence $u = t_1 t_2 \dots t_m$.

A transition t is *enabled* at a marking M if $M(p) \geq W(p, t)$ for every place p . A transition t enabled at M may *fire* or *occur* yielding the marking $M' = M + \Delta(t)$. This is denoted by $M \xrightarrow{t} M'$. For any $a \in Act$, $M \xrightarrow{a} M'$ denotes that $M \xrightarrow{t} M'$ for some transition t such that $\ell(t) = a$. These definitions are homomorphically extended to finite sequences of transitions and finite sequences of actions. $M \longrightarrow M'$ denotes that there exists some sequence u of transitions such that $M \xrightarrow{u} M'$.

The *reachability set* of a marking M is $\mathcal{R}(M) = \{M' \mid M \longrightarrow M'\}$. The reachability set of N is $\mathcal{R}(N) = \mathcal{R}(M_0)$. The transition system of N has $\mathcal{R}(N)$ as set of states, the initial marking M_0 as initial state, and the relations \xrightarrow{a} between markings as relations.

Let N_1 and N_2 be two nets. A *strong bisimulation* is a relation \mathcal{B} between the markings of N_1 and N_2 such that for all $(M_1, M_2) \in \mathcal{B}$ and for all $a \in Act$:

- if $M_1 \xrightarrow{a} M'_1$ then $M_2 \xrightarrow{a} M'_2$ for some M'_2 such that $(M'_1, M'_2) \in \mathcal{B}$; and
- if $M_2 \xrightarrow{a} M'_2$ then $M_1 \xrightarrow{a} M'_1$ for some M'_1 such that $(M'_1, M'_2) \in \mathcal{B}$.

For every action $a \in Act \setminus \{\tau\}$, define $\xrightarrow{a} = (\xrightarrow{\tau})^* \xrightarrow{a} (\xrightarrow{\tau})^*$; define also $\xrightarrow{\tau} = (\xrightarrow{\tau})^*$. A relation \mathcal{B} between the markings of N_1 and N_2 is a *weak bisimulation* if for all $(M_1, M_2) \in \mathcal{B}$ and for all $a \in Act$:

- if $M_1 \xrightarrow{a} M'_1$ then $M_2 \xrightarrow{a} M'_2$ for some M'_2 such that $(M'_1, M'_2) \in \mathcal{B}$; and
- if $M_2 \xrightarrow{a} M'_2$ then $M_1 \xrightarrow{a} M'_1$ for some M'_1 such that $(M'_1, M'_2) \in \mathcal{B}$.

M_1 is *strongly bisimilar* to M_2 , denoted by $M_1 \sim M_2$, if $(M_1, M_2) \in \mathcal{B}$ for some strong bisimulation \mathcal{B} . Similarly, M_1 is *weakly bisimilar* to M_2 , denoted by $M_1 \approx M_2$, if $(M_1, M_2) \in \mathcal{B}$ for some weak bisimulation \mathcal{B} . Two nets are strongly (weakly) bisimilar if their initial markings are strongly (weakly) bisimilar.

Notice that in the case of strong bisimulation τ plays the same rôle as any other action.

We use a stratified characterisation of strong bisimulation. Given two nets N_1 and N_2 , the relations \sim_i between their sets of markings are inductively defined as follows. First, we stipulate that $M_1 \sim_0 M_2$ for all pairs (M_1, M_2) . Then for every $n \in \mathbb{N}$ we let $M_1 \sim_{n+1} M_2$ whenever for every $a \in Act$:

- if $M_1 \xrightarrow{a} M'_1$ then $M_2 \xrightarrow{a} M'_2$ for some M'_2 such that $M'_1 \sim_n M'_2$; and
- if $M_2 \xrightarrow{a} M'_2$ then $M_1 \xrightarrow{a} M'_1$ for some M'_1 such that $M'_1 \sim_n M'_2$.

Clearly, \sim_i is an equivalence relation, and $\sim_{i+1} \subseteq \sim_i$ for every $i \geq 0$. Again we apply these relations to nets by considering their initial marking.

For every action a and every marking M of a net N , the set of markings M' such that $M \xrightarrow{a} M'$ is finite, because N has finitely many transitions. It is well known that in this case we have $M_1 \sim M_2$ iff $M_1 \sim_n M_2$ for every $n \in \mathbb{N}$; moreover, the problem ‘Is $N_1 \sim_n N_2$?’ is decidable for every $n \in \mathbb{N}$.

We also make use of the following property:

Proposition 2.1

Let $N = (P, T, W, M_0, \ell)$ be a net, and let $k = \max\{W(p, t) \mid p \in P, t \in T\}$. Let M_1, M_2 be two markings of N satisfying the following property: for some number n and for every place p , $M_1(p) \neq M_2(p)$ implies $M_1(p) \geq kn$ and $M_2(p) \geq kn$. Then $M_1 \sim_n M_2$.

Proof: The occurrence of a transition removes at most k tokens from a place. Therefore, the transition systems of N with M_1 and M_2 as initial markings are isomorphic up to depth n , which implies $M_1 \sim_n M_2$. ■ 2.1

Notice that every finite transition system is the transition system of some net up to renaming of the states. Using this fact we can immediately extend the definitions above to the case in which N_1 and/or N_2 is replaced by a finite transition system. We use R to denote a finite transition system, r, r' for its states, and r_0 for its initial state.

To finish the section we formally define the problems we are going to study

Strong equivalence problem:

Instance: a Petri net N , and a finite transition system R .

Question: is $N \sim R$?

Strong finiteness problem:

Instance: a Petri net N

Question: is N finite with respect to strong bisimilarity (*b-finite*, for short), i.e. is there a finite transition system R such that $N \sim R$?

We also study the *weak equivalence problem* and the *weak finiteness problem*, which are defined analogously, substituting weak bisimulation (\approx) for strong bisimulation (\sim), and *weakly b-finite* for b-finite.

3 Auxiliary results

We recall a well-known lemma, which can be easily proved by induction on $|P|$:

Lemma 3.1 *Dickson's Lemma*

Given an infinite sequence of mappings M_1, M_2, M_3, \dots of the type $P \rightarrow \mathbb{N}$, for a finite set P , there are indices $1 \leq i_1 < i_2 < i_3 < \dots$ such that $M_{i_1} \leq M_{i_2} \leq M_{i_3} \dots$ (\leq defined componentwise).

We also need a semidecidability result, which uses the following notions. A set $\mathcal{M} \subseteq \mathbb{N}^P$ (where P is a finite set) is *linear* if there exist M_b (basis), and M_1, \dots, M_n (periods) in \mathbb{N}^P such that

$$\mathcal{M} = \{M_b + \sum_{i=1}^n a_i M_i \mid a_1, \dots, a_n \in \mathbb{N}\}.$$

We call $p \in P$ *increasible* in \mathcal{M} iff $M_i(p) > 0$ for some $1 \leq i \leq n$.

Lemma 3.2

Let N be a Petri net with initial marking M_0 , and let $\mathcal{M}_1, \mathcal{M}_2$ be linear sets of markings of N . It is semidecidable if the set

$$\mathcal{M}_{12} = \{M_1 \in \mathcal{M}_1 \mid \exists M_2 \in \mathcal{M}_2: M_0 \longrightarrow M_1 \longrightarrow M_2\}$$

contains markings with arbitrarily large values on places which are increasible in \mathcal{M}_1 (i.e., for any k there is $M_k \in \mathcal{M}_{12}$ such that $M_k(p) > k$ for each increasible p).²

Proof: Apply Higman's lemma as in [6]. The question is then reduced to the existence of transition sequences $u_1, u_2, \dots, u_m, v_1, v_2, \dots, v_{m'}, w_1, w_2, \dots, w_{m+m'}$ (for some m, m') such that

$$M_0 \xrightarrow{u_1 u_2 \dots u_m} M_1 \xrightarrow{v_1 v_2 \dots v_{m'}} M_2$$

and

$$M_0 \xrightarrow{u_1 w_1 u_2 w_2 \dots u_m w_m} M'_1 \xrightarrow{v_1 w_{m+1} v_2 w_{m+2} \dots v_{m'} w_{m+m'}} M'_2$$

where $M_i, M'_i \in \mathcal{M}_i$ for $i = 1, 2$, $M'_1(p) > M_1(p)$ for each p increasible in \mathcal{M}_1 , and $\Delta(w_1 w_2 \dots w_j) \geq (0, 0, \dots, 0)$ for every $j = 1, 2, \dots, m + m'$. The existence of such sequences is obviously semidecidable. ■ 3.2

4 Decidability of strong equivalence

The strong equivalence problem has already been shown to be decidable in [10]. The proof given there relies on some general results about semilinear sets and Presburger arithmetic. Here we look in greater detail at the \sim_n equivalence classes, which enables us to give a more self contained proof. All the lemmas of this section are also used in the next one.

We consider ordinary nets, because Proposition 2.1 has a particularly simple form for them. The results can be easily generalised to arbitrary nets by carrying the constant k of Proposition 2.1 through the proofs.

²Ernst Mayr has observed that this problem is probably even decidable.

We fix an ordinary Petri net $N = (P, T, W, M_0, \ell)$, and a finite transition system R having n states and initial state r_0 .

We start with a simple observation. Given two states r and r' of R , we have $r \sim_n r'$ whenever $r \sim_{n-1} r'$. This is easily seen to be true by noting that the sequence of approximation equivalences \sim_0, \sim_1, \dots on the states of R must stabilise within n steps (every equivalence relation on this set has at most n equivalence classes).

We examine the structure of the classes \sim_n on the set of (all) markings of N .

Definition 4.1 *n-bounded markings, markings incompatible with R*

A marking L of N is *n-bounded* if $L \leq (n, n, \dots, n)$. For every n -bounded marking L , we define $L^{\geq n}$ as the set of markings M satisfying the following two properties

- if $L(p) < n$, then $M(p) = L(p)$; and
- if $L(p) = n$, then $M(p) \geq L(p)$.

A marking M of N is *incompatible with R* if $M \not\sim_n r$ for every state r of R . The set of markings incompatible with R is denoted by $Inc(R)$. ■ 4.1

In the sequel we use the symbols L, L_1, L_2 for n -bounded markings. Note that $M_1 \sim_n M_2$ for any $M_1, M_2 \in L^{\geq n}$ (cf. Proposition 2.1), and that there are only finitely many n -bounded markings. Obviously, $Inc(R) = L_1^{\geq n} \cup \dots \cup L_k^{\geq n}$ for some k , where L_i is n -bounded for $1 \leq i \leq k$.

Lemma 4.2 *Characterization of strong equivalence*

$N \sim R$ iff the following two conditions hold:

- (1) $N \sim_n R$; and
- (2) $\mathcal{R}(N) \cap L^{\geq n} = \emptyset$ for every n -bounded marking $L \in Inc(R)$.

Proof: (\Rightarrow): (1) follows immediately from the definitions. For (2), let L be an n -bounded marking such that $L \in Inc(R)$. Then $L^{\geq n} \subseteq Inc(R)$. Since $N \sim R$, every marking of $\mathcal{R}(N)$ is bisimilar to some state of R , and so $\mathcal{R}(N) \cap Inc(R) = \emptyset$. Therefore $\mathcal{R}(N) \cap L^{\geq n} = \emptyset$.

(\Leftarrow): Define $\mathcal{B} = \{(M, r) \mid M \in \mathcal{R}(N) \text{ and } M \sim_n r\}$. We show that \mathcal{B} is a strong bisimulation containing (M_0, r_0) . $(M_0, r_0) \in \mathcal{B}$ follows from (1). Let $(M, r) \in \mathcal{B}$ and assume $M \xrightarrow{a} M'$ for some action a . Then there exists a state r' such that $r \xrightarrow{a} r'$ and $M' \sim_{n-1} r'$. We have $M' \in \mathcal{R}(N)$ and $M' \in L^{\geq n}$ for some n -bounded marking L . It follows from (2) that $L \notin Inc(R)$, and hence R contains a state r'' such that $M' \sim_n r''$. So we get $r' \sim_{n-1} r''$. By our observation at the beginning of the section, $r' \sim_n r''$, and hence $M' \sim_n r'$. This implies $(M', r') \in \mathcal{B}$, and so \mathcal{B} is a strong bisimulation. ■ 4.2

Theorem 4.3 *Decidability of strong equivalence (see also [10])*

It is decidable whether $N \sim R$ or not.

Proof: It suffices to prove that (1) and (2) in Lemma 4.2 are decidable. (1) is clearly decidable. Since there exist finitely many n -bounded markings, the set of n -bounded markings $L \in Inc(R)$ is effectively constructible. The decidability of the reachability problem for submarkings [3] easily implies the decidability of the problem $\mathcal{R}(N) \cap L^{\geq n} = \emptyset$ for a given n -bounded marking L . So (2) is decidable as well. ■ 4.3

5 Decidability of strong finiteness

In this section we prove that the strong finiteness problem is decidable. Again, the proof is carried out for ordinary nets, but it can be easily generalised.

Since the strong equivalence problem is decidable, the strong finiteness problem is semidecidable. Therefore, it suffices to prove semidecidability of the

Strong infiniteness problem:

Instance: a Petri net N

Question: is N infinite with respect to strong bisimilarity (*b-infinite*, for short), i.e., has N infinitely many reachable markings M_1, M_2, M_3, \dots such that $M_i \not\sim M_j$ for $i \neq j$?

We fix an ordinary Petri net $N = (P, T, W, M_0, \ell)$ for the rest of the section, and introduce a little notation. Let P_1, P_2 be a partition of P such that $P_2 \neq \emptyset$, and let $M_1: P_1 \rightarrow \mathbb{N}$, $M_2: P_2 \rightarrow \mathbb{N}$. (M_1, M_2) denotes the marking of N whose projection on P_1 is M_1 , and whose projection on P_2 is M_2 . $(M_1, -)$ denotes the marking M_1 of the net obtained from N by removing all places that do not belong to P_1 , together with their incident arcs. We make abuse of language, and speak of ‘the marking $(M_1, -)$ of N ’.

An argument similar to that of Proposition 2.1 proves that $M' \geq (i, \dots, i)$ for some number i implies $(M, M') \sim_i (M, -)$.

Lemma 5.1

If $(M, M_1) \sim (M, M_2) \sim (M, M_3) \sim \dots$ and $M_1 < M_2 < M_3 \dots$ ($<$ defined componentwise), then $(M, M_1) \sim (M, -)$.

Proof: For every $i \geq 0$ there surely exists an index j such that $M_j \geq (i, i, \dots, i)$. Then $(M, -) \sim_i (M, M_j)$ holds and, since $(M, M_1) \sim (M, M_j)$, we also have $(M, -) \sim_i (M, M_1)$. Therefore, $(M, -) \sim_i (M, M_1)$ for every $i \geq 0$, and so $(M, -) \sim (M, M_1)$. ■ 5.1

Lemma 5.2 Characterization of b-infiniteness

N is b-infinite iff there exists a marking $(M, -)$ of N such that some of the following two condition holds:

- (1) *$(M, -)$ is b-infinite and there exists a chain $M_1 < M_2 < M_3 \dots$ such that $(M, M_i) \in \mathcal{R}(N)$ for every $i \geq 1$, or*
- (2) *$(M, -)$ is b-finite and there exists a chain $M_1 < M_2 < M_3 \dots$ such that $(M, M_i) \in \mathcal{R}(N)$ and $(M, M_i) \not\sim (M, -)$ for every $i \geq 1$.*

Proof: (\Rightarrow): If N is b-infinite, then there exists an infinite set of pairwise non-bisimilar reachable markings. By Dickson’s Lemma, we can extract from this set an infinite subsequence $(M, M_1), (M, M_2), (M, M_3), \dots$ such that $M_1 < M_2 < M_3 < \dots$. So either (1) or (2) holds, according to whether $(M, -)$ is b-finite or b-infinite.

(\Leftarrow): Assume (1) holds, and let $\mathcal{M} = \{(M, M_i) \mid i \geq 1\}$. If \mathcal{M} contains infinitely many pairwise non-bisimilar markings, then N is b-infinite, and we are done. Otherwise, \mathcal{M} contains infinitely many pairwise bisimilar markings. By Lemma 5.1, all these markings are bisimilar to $(M, -)$ and hence b-infinite. So N is b-infinite. Assume now that (2) holds. If \mathcal{M} contains infinitely many pairwise bisimilar markings, then by Lemma 5.1 all of them are bisimilar to $(M, -)$, contradicting the condition $(M, M_i) \not\sim (M, -)$ for every $i \geq 0$. So \mathcal{M} contains infinitely many pairwise non-bisimilar markings, which implies that N is b-infinite. ■ 5.2

Theorem 5.3 *Decidability of strong finiteness*

It is decidable whether N is b-finite or not.

Proof: We proceed by induction on the number of places of N . If N has no places, then it is clearly b-finite. Assume now that N has some place. By Theorem 4.3, the b-finiteness of N is semidecidable. So it suffices to prove that the b-infiniteness of N is also semidecidable, or, equivalently, that conditions (1) and (2) of Lemma 5.2 are semidecidable.

For that, we enumerate all markings $(M, -)$ of N for all partitions P_1, P_2 such that $P_2 \neq \emptyset$. Given a marking $(M, -)$, we can decide by induction hypothesis if it is b-finite or b-infinite; moreover:

(1) The existence of a chain $M_1 < M_2 < M_3 \dots$ such that $(M, M_i) \in \mathcal{R}(N)$ for every $i \geq 1$ is semidecidable.

Let \mathcal{M}_1 be the set of all markings of the form (M, M') ; it is obviously a linear set where exactly the places of P_2 are increasible. Now the desired semidecidability follows from Lemma 3.2 (putting e.g. $\mathcal{M}_2 = \mathcal{M}_1$).

(2) If $(M, -)$ is finite, then the existence of a chain $M_1 < M_2 < M_3 \dots$ such that $(M, M_i) \in \mathcal{R}(N)$ and $(M, M_i) \not\prec (M, -)$ for every $i \geq 1$ is semidecidable.

Assume that $(M, -)$ is finite. Then by exhaustive search and Theorem 4.3 a finite transition system R can be found such that $(M, -) \sim R$. Let n denote the number of states of R .

Say a chain is *adequate* if it satisfies the conditions of (2). We prove that there exists an adequate chain iff there exists an n -bounded marking L of N satisfying the following two conditions

- (a) $L \in \text{Inc}(R)$; and
- (b) there exists a chain $M_1 < M_2 < M_3 \dots$ and markings $M'_1, M'_2, M'_3, \dots \in L^{\geq n}$ such that $M_0 \longrightarrow (M, M_i) \longrightarrow M'_i$ for every $i \geq 1$.

(\Rightarrow): Let $M_1 < M_2 < M_3 \dots$ be an adequate chain. There exists an index i_0 such that $M_i \geq (n, n, \dots, n)$ for every $i \geq i_0$. For $i \geq i_0$ we have $(M, M_i) \not\prec (M, -)$ by assumption (and so $(M, M_i) \not\prec R$), but $(M, M_i) \sim_n (M, -)$ (and so $(M, M_i) \sim_n R$). By Lemma 4.2 there exists an n -bounded marking $L_i \in \text{Inc}(R)$ such that $\mathcal{R}((M, M_i)) \cap L_i^{\geq n} \neq \emptyset$.

By the pigeonhole principle there exists an n -bounded marking L and infinitely many indices $i_1 < i_2 < i_3 \dots$ such that $L = L_{i_1} = L_{i_2} \dots$. Clearly, L satisfies (a) and the subchain $M_{i_1} < M_{i_2} < M_{i_3} \dots$ satisfies (b).

(\Leftarrow): Let M_i be an arbitrary marking of the chain given by (b). We prove $(M, M_i) \not\prec (M, -)$, which shows that the chain is adequate. Since $M_0 \longrightarrow (M, M_i) \longrightarrow M'_i$ for some marking $M'_i \in L^{\geq n}$, we have $\mathcal{R}((M, M_i)) \cap L^{\geq n} \neq \emptyset$. By (a) and Lemma 4.2 we have $(M, M_i) \not\prec R$, which together with $(M, -) \sim R$ implies $(M, M_i) \not\prec (M, -)$.

It remains to prove the semidecidability of conditions (a) and (b) for a given n -bounded marking L . Condition (a) is clearly decidable. For condition (b), apply Lemma 3.2 with \mathcal{M}_1 as the set of markings of N of the form (M, M') , and $\mathcal{M}_2 = L^{\geq n}$. Note that \mathcal{M}_1 and \mathcal{M}_2 are linear sets.

■ 5.3

6 Undecidability of weak equivalence

We show that the weak equivalence problem is undecidable. In fact, we prove that none of the problems $N \approx R$ and $N \not\approx R$ is semidecidable. As a corollary of this result, we also find a fixed transition system R_{fix} with 7 states such that $N \approx R_{fix}$ is undecidable.

The proof is by reduction from the

Containment problem:

Instance: two Petri nets N_1, N_2 having the same number of places, and a bijection f from the places of N_1 onto the places of N_2 .

Question: is $f(\mathcal{R}(N_1)) \subseteq \mathcal{R}(N_2)$? (where f is extended to markings and sets of markings in the obvious way.)

The undecidability of this problem was proved by Rabin by means of a reduction from Hilbert's 10th problem. A reduction from the halting problem for counter machines can be found in [9]. Let $N_1 = (P_1, T_1, W_1, M_{10}, \ell_1)$, $N_2 = (P_2, T_2, W_2, M_{20}, \ell_2)$ be two Petri nets, and let $f: P_1 \rightarrow P_2$ be a bijection. We construct another net N which is weakly bisimilar to the state r_1 of the finite transition system R shown in Figure 1 if $f(\mathcal{R}(N_1)) \not\subseteq \mathcal{R}(N_2)$ and weakly bisimilar to the state r_5 if $f(\mathcal{R}(N_1)) \subseteq \mathcal{R}(N_2)$. (The state r_0 of R is used in the next section.) Without loss of generality, we assume that (a) the sets of places and transitions of N_1 and N_2 are disjoint, (b) $f(M_{10}) = M_{20}$, (c) $|\mathcal{R}(N_2)| \geq 2$, and (d) $(0, \dots, 0) \notin \mathcal{R}(N_1) \cup \mathcal{R}(N_2)$.

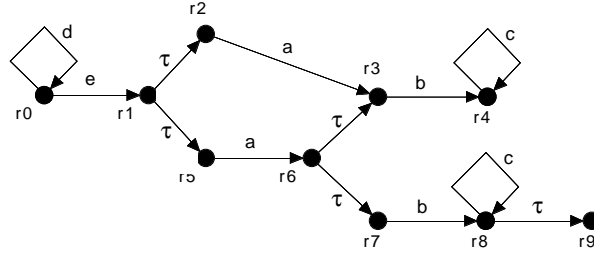

Figure 1: The transition system R

Instead of giving a formal definition of N , which would be tedious, we describe it informally at a level of detail which suffices to follow the proof. We need the following notion: a place p is a *run place* of a set T of transitions if $W(p, t) = 1 = W(t, p)$ for every $t \in T$. The transitions of T can only occur when p holds at least one token.

Figure 2 shows a schema of the net N . To construct N , we first take the union of N_1 and N_2 (the sets of places and transitions of N_1 and N_2 are disjoint by assumption (a)), labelling all transitions by τ . Then we add some further places and transitions: the place p_1 is a run-place of T_1 (graphically represented by a double pointed white arrow). This token can be moved by a new τ -transition t_1 to a place p'_1 , and then by an a -transition t'_1 to p_2 , which is a run-place of T_2 . From p_2 , the token can be moved by another τ -transition t_2 to p'_2 and by a b -transition t'_2 to p_3 , which is a run-place of an additional set of transitions. This set contains:

- a τ -transition for every pair $(p, f(p))$ of places of N_1 and N_2 . The transition has p and $f(p)$ as input places, and no output place – when it occurs, it simultaneously decreases the marking of p and $f(p)$;

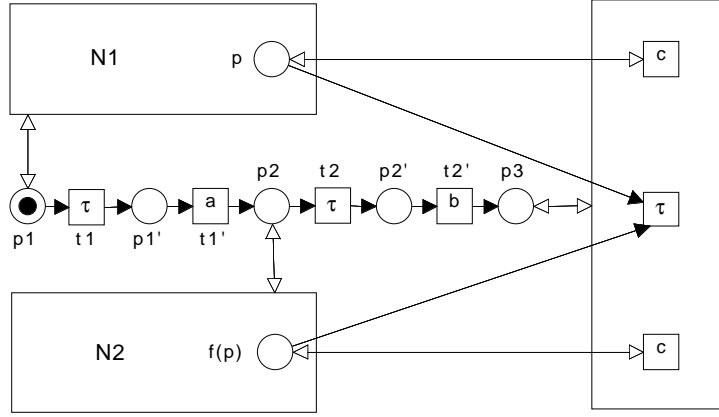

Figure 2: Scheme net N

- a c -transition for each place p of N_1 and N_2 ; the transition has p as unique input and output place.

We denote a marking of N as a vector with three components: the first and the third components are the projections of the marking on N_1 and N_2 , respectively, while the second indicates which place of the set $\{p_1, p'_1, p_2, p'_2, p_3\}$ currently holds a token. The initial marking of N is (M_{10}, p_1, M_{20}) .

From the initial marking, N can execute some τ -moves corresponding to transitions of N_1 . If at some moment t_1 occurs (this is also a τ -move), then a marking (M_1, p'_1, M_{20}) is reached, and the marking M_1 becomes ‘frozen’. Then, after an a -move, N can execute some τ -moves corresponding to transitions of N_2 . Again, if at some moment t_2 occurs, then a marking (M_1, p'_2, M_2) is reached, and the marking M_2 becomes ‘frozen’.

Proposition 6.1

If $f(\mathcal{R}(N_1)) \subseteq \mathcal{R}(N_2)$, then $N \approx r_5$. If $f(\mathcal{R}(N_1)) \not\subseteq \mathcal{R}(N_2)$, then $N \approx r_1$.

Proof: Consider a marking of N of the form (M_1, p_3, M_2) , where $M_1 \neq (0, \dots, 0) \neq M_2$. Two cases are possible:

- if $M_1 \neq M_2$ then the action c (the only visible action that can still occur) is permanently enabled; hence $(M_1, p_3, M_2) \approx r_4$;
- if $M_1 = M_2$, then c can be disabled at any time; hence $(M_1, p_3, M_2) \approx r_8$.

It follows easily (using assumption (d)) that any reachable marking of N of the form (M_1, p_2, M_2) is weakly bisimilar to r_7 if $f(M_1)$ is the *only* marking reachable from M_2 ; to r_3 if $f(M_1)$ is not reachable from M_2 in N_2 ; and to r_6 otherwise.

Similarly, any reachable marking of N of the form (M_1, p'_1, M_{20}) is weakly bisimilar to r_2 if $f(M_1) \notin \mathcal{R}(N_2)$, and to r_5 otherwise; in the latter case we are using assumption (c), $|\mathcal{R}(N_2)| \geq 2$, which implies that N_2 can reach a marking different from $f(M_1)$.

Finally, we consider the initial marking (M_{10}, p_1, M_{20}) :

- if $f(\mathcal{R}(N_1)) \subseteq \mathcal{R}(N_2)$ then $(M_{10}, p_1, M_{20}) \approx r_5$, because $f(M_1) \in \mathcal{R}(N_2)$ for every reachable marking of the form (M_1, p'_1, M_{20}) ;
- if $f(\mathcal{R}(N_1)) \not\subseteq \mathcal{R}(N_2)$ then $(M_{10}, p_1, M_{20}) \approx r_1$, because from (M_{10}, p_1, M_{20}) we can reach both (M_{10}, p'_1, M_{20}) , which is weakly bisimilar to r_5 because of assumption (b), and a marking (M'_1, p'_1, M_{20}) satisfying $M'_1 \notin \mathcal{R}(N_2)$, which is weakly bisimilar to r_2 . ■ 6.1

Theorem 6.2

Neither the weak equivalence problem nor the weak non-equivalence problem are semidecidable.

Proof: Notice first that $r_1 \not\approx r_5$ (it is easy to show successively that $r_4 \not\approx r_8$, $r_3 \not\approx r_7$, $r_3 \not\approx r_6$, and $r_2 \not\approx r_5$, and hence $r_1 \not\approx r_5$). By Proposition 6.1 we have

- $f(\mathcal{R}(N_1)) \subseteq \mathcal{R}(N_2)$ iff $N \approx r_5$ iff $N \not\approx r_1$; and
- $f(\mathcal{R}(N_1)) \not\subseteq \mathcal{R}(N_2)$ iff $N \approx r_1$ iff $N \not\approx r_5$.

The result now follows easily. ■ 6.2

It follows from the proof of this theorem that the problem $N \approx r_5$ is undecidable. The transition system R_{fix} announced at the beginning of the section is obtained by removing r_0, \dots, r_4 from R , together with their adjacent arcs.

7 Undecidability of the weak finiteness problem

We show the undecidability of the weak finiteness problem by means of a reduction from the

Halting problem for 2-counter machines and 0-input:

Instance: a 2-counter machine C .

Question: does C halt when both counters are initialised to 0?

whose undecidability is well known [12]. Let C be an arbitrary 2-counter machine. We construct another 2-counter machine C' which for input $(x, 0)$ computes as follows: first, it checks if $x = 2^k$ for some $k \geq 0$; if this is the case, then it sets the counters to 0 and simulates C , otherwise it halts. We have:

- if C halts for $(0, 0)$, then C' halts for every input $(x, 0)$, $x \geq 0$;
- if C does not halt for $(0, 0)$ then C' halts for $(x, 0)$ iff x is not a power of 2.

We now use a procedure described in [9]: it accepts the 2-counter machine C' and outputs two nets N_1, N_2 with distinguished places c_{11}, c_{12} and c_{21}, c_{22} (initially unmarked), together with a bijection f between the places of N_1 and N_2 satisfying $f(c_{11}) = c_{21}$ and $f(c_{12}) = c_{22}$. N_1 and N_2 satisfy the following property for every $x \geq 0$:

$$C' \text{ halts for input } (x, 0) \quad \text{iff} \quad f(\mathcal{R}(N_1^{x,0})) \not\subseteq \mathcal{R}(N_2^{x,0})$$

where $N_i^{x,0}$ denotes the result of changing the initial marking of N_i by putting exactly x tokens on c_{i1} .

We apply the construction of the last section to the nets N_1 and N_2 , and obtain this way a net N . We modify this net in the following way. First, we remove the token from p_1 . Second, we add some new places and transitions:

- a place p_0 , initially marked with one token;
- a d -transition with p_0 as only input place, and p_0 , c_{11} and c_{21} as output places (i.e., p_0 is a run-place for this transition);
- an e -transition, with p_0 as input place and p_1 as output place.

Let N' be the result of this modification. From its initial marking, N' can repeatedly execute the d -transition, by which it puts an arbitrary number of tokens x on the places c_{11} and c_{21} . Then, it may execute the e -transition. After that, the place p_1 carries a token, and N' behaves like the net we would obtain by applying the construction of the last section to $N_1^{x,0}$ and $N_2^{x,0}$.

Proposition 7.1

N' is weakly b-finite iff the counter machine C halts for $(0, 0)$.

Proof: (\Rightarrow): If C does not halt for $(0, 0)$ then C' halts for $(x, 0)$ iff x is not a power of 2. Therefore $f(\mathcal{R}(N_1^{x,0})) \subseteq \mathcal{R}(N_2^{x,0})$ if $x = 2^k$ for some $k \geq 0$, and $f(\mathcal{R}(N_1^{x,0})) \not\subseteq \mathcal{R}(N_2^{x,0})$ otherwise. Let R be the transition system of Figure 1 with states r_0, \dots, r_9 . We have for any x and the unique marking M reached after executing the sequence d^x in N' :

- (1) if x is not a power of 2 then there is M' s.t. $M \xrightarrow{c} M'$ and $M' \approx r_1$;
- (2) if x is a power of 2 then there is no such M' .

We prove that N' is weakly b-infinite by contradiction. Assume that N' is weakly bisimilar to some transition system R' with n states. Let r'_0 be the initial state of R' , and let r' be a state such that $r'_0 \xrightarrow{u} r'$, where u is a sequence of actions whose projection on the set of visible actions is d^{2^n} . By the pumping lemma, $r'_0 \xrightarrow{vw^ix} r'$ for sequences v, w, x and for every $i \geq 0$, where $u = vwx$ and the projection of w on the set of visible actions is a nonempty sequence of d 's. By (1) and (2) we have that there is r'' in R' s.t. $r' \xrightarrow{c} r''$ and $r'' \approx r_1$, and at the same time there is no such r'' – a contradiction. (\Leftarrow): If C halts for $(0, 0)$, then C' halts for every input $(x, 0)$, $x \geq 0$. Therefore after the occurrence of the e -transition we always have $f(\mathcal{R}(N_1^{x,0})) \subseteq \mathcal{R}(N_2^{x,0})$, independently of the value of x . It is then clear that $N' \approx r_0$. So N' is weakly b-finite. ■ 7.1

Theorem 7.2

Neither the weak finiteness problem nor the weak infiniteness problems are semidecidable.

Proof: By Proposition 7.1, C does not halt for $(0, 0)$ iff N' is weakly b-infinite. So the weak infiniteness problem is not semidecidable. We can also change C' in the following way: if x is not a power of 2, then C' enters an infinite loop. In this case, C does not halt iff the net N' is weakly b-infinite. So the weak finiteness problem is not semidecidable either. ■ 7.2

8 Conclusions

The results of this paper, together with those of [13, 10] and some unpublished results of [8], yield the following picture about the equivalence and finiteness problems for labelled Petri nets:

	Language	Trace	Bisimulation
strong equivalence	U	D	D
weak equivalence	U	D	U
strong finiteness	U	U	D
weak finiteness	U	U	U

Mauw and Mulder have recently studied the finiteness problem for Basic Process Algebra, instead of Petri nets [11]. Their results are similar to ours: the problem is undecidable for trace equivalence, but decidable for bisimulation equivalence. Finally, since BPP are bisimilar to a particular class of Petri nets (called communication-free nets in [4]), the decidability of the finiteness problem for BPP and bisimulation follows as a corollary of our results.

References

- [1] S. Christensen, Y. Hirshfeld, and F. Moller. Bisimulation Equivalence is Decidable for all Basic Parallel Processes. In *Proceedings of CONCUR '93*, volume 715 of *Lecture Notes in Computer Science*, pages 143–157, 1993.
- [2] S. Christensen, H. Hüttel, and C. Stirling. Bisimulation Equivalence is Decidable for all Context-free Processes. In *Proceedings of CONCUR '92*, volume 630 of *Lecture Notes in Computer Science*, pages 138–147, 1992.
- [3] J. Esparza and M. Nielsen. Decidability issues for Petri nets – a survey. In *Bulletin of the EATCS*, volume 52, pages 245–262, 1994
Also: *Journal of Information Processing and Cybernetics* 30(3):143–160, 1995.
- [4] Y. Hirshfeld. Petri Nets and the Equivalence Problem. In *Proceedings of CSL '93*, volume 832 of *Lecture Notes in Computer Science*, pages 165–174, 1994.
- [5] J. E. Hopcroft and J. Ullman. *Introduction to Automata Theory, Languages and Computation*. Addison-Wesley, 1979.
- [6] P. Jančár. Decidability of a temporal logic problem for Petri Nets. *Theoretical Computer Science*, 74:71–93, 1990.
- [7] P. Jančár. All action-based behavioural equivalences are undecidable for labelled Petri nets. *Bulleting of EATCS*, 56:86–88, 1995.
- [8] P. Jančár. Decidability Questions for equivalences in Petri Nets. Technical report, University of Ostrava, habilitation thesis, 1995.
- [9] P. Jančár. Undecidability of bisimilarity for Petri nets and some related problems. *Theoretical Computer Science*, 148:281–301, 1995.
- [10] P. Jančár and F. Moller. Checking Regular Properties of Petri Nets. In *Proceedings of CONCUR '95*, volume 995 of *Lecture Notes in Computer Science*, pages 348–362, 1995.
- [11] S. Mauw and H. Mulder. Regularity of BPA-systems is decidable. In *Proceedings of CONCUR '94*, volume 836 of *Lecture Notes in Computer Science*, pages 34–47, 1994.
- [12] M. Minsky. *Computation: Finite and Infinite Machines*. Prentice Hall, 1967.
- [13] R. Valk and G. Vidal-Naquet. Petri Nets and regular Languages. *Journal of Computer and system Sciences*, 23(3):299–325, 1981.

SFB 342: Methoden und Werkzeuge für die Nutzung paralleler
Rechnerarchitekturen

bisher erschienen :

Reihe A

- 342/1/90 A Robert Gold, Walter Vogler: Quality Criteria for Partial Order Semantics of Place/Transition-Nets, Januar 1990
- 342/2/90 A Reinhard Fößmeier: Die Rolle der Lastverteilung bei der numerischen Parallelprogrammierung, Februar 1990
- 342/3/90 A Klaus-Jörn Lange, Peter Rossmanith: Two Results on Unambiguous Circuits, Februar 1990
- 342/4/90 A Michael Griebel: Zur Lösung von Finite-Differenzen- und Finite-Element-Gleichungen mittels der Hierarchischen Transformations-Mehrgitter-Methode
- 342/5/90 A Reinhold Letz, Johann Schumann, Stephan Bayerl, Wolfgang Bibel: SETHEO: A High-Performance Theorem Prover
- 342/6/90 A Johann Schumann, Reinhold Letz: PARTHEO: A High Performance Parallel Theorem Prover
- 342/7/90 A Johann Schumann, Norbert Trapp, Martin van der Koelen: SETHEO/PARTHEO Users Manual
- 342/8/90 A Christian Suttner, Wolfgang Ertel: Using Connectionist Networks for Guiding the Search of a Theorem Prover
- 342/9/90 A Hans-Jörg Beier, Thomas Bemmerl, Arndt Bode, Hubert Ertl, Olav Hansen, Josef Haunerding, Paul Hofstetter, Jaroslav Kremenek, Robert Lindhof, Thomas Ludwig, Peter Luksch, Thomas Tremml: TOPSYS, Tools for Parallel Systems (Artikelsammlung)
- 342/10/90 A Walter Vogler: Bisimulation and Action Refinement
- 342/11/90 A Jörg Desel, Javier Esparza: Reachability in Reversible Free- Choice Systems
- 342/12/90 A Rob van Glabbeek, Ursula Goltz: Equivalences and Refinement
- 342/13/90 A Rob van Glabbeek: The Linear Time - Branching Time Spectrum
- 342/14/90 A Johannes Bauer, Thomas Bemmerl, Thomas Tremml: Leistungsanalyse von verteilten Beobachtungs- und Bewertungswerkzeugen
- 342/15/90 A Peter Rossmanith: The Owner Concept for PRAMs
- 342/16/90 A G. Böckle, S. Trosch: A Simulator for VLIW-Architectures
- 342/17/90 A P. Slavkovsky, U. Rüde: Schnellere Berechnung klassischer Matrix-Multiplikationen
- 342/18/90 A Christoph Zenger: SPARSE GRIDS
- 342/19/90 A Michael Griebel, Michael Schneider, Christoph Zenger: A combination technique for the solution of sparse grid problems

Reihe A

- 342/20/90 A Michael Griebel: A Parallelizable and Vectorizable Multi- Level- Algorithm on Sparse Grids
- 342/21/90 A V. Diekert, E. Ochmanski, K. Reinhardt: On confluent semi-commutations-decidability and complexity results
- 342/22/90 A Manfred Broy, Claus Dendorfer: Functional Modelling of Operating System Structures by Timed Higher Order Stream Processing Functions
- 342/23/90 A Rob van Glabbeek, Ursula Goltz: A Deadlock-sensitive Congruence for Action Refinement
- 342/24/90 A Manfred Broy: On the Design and Verification of a Simple Distributed Spanning Tree Algorithm
- 342/25/90 A Thomas Bemmerl, Arndt Bode, Peter Braun, Olav Hansen, Peter Luksch, Roland Wismüller: TOPSYS - Tools for Parallel Systems (User's Overview and User's Manuals)
- 342/26/90 A Thomas Bemmerl, Arndt Bode, Thomas Ludwig, Stefan Tritscher: MMK - Multiprocessor Multitasking Kernel (User's Guide and User's Reference Manual)
- 342/27/90 A Wolfgang Ertel: Random Competition: A Simple, but Efficient Method for Parallelizing Inference Systems
- 342/28/90 A Rob van Glabbeek, Frits Vaandrager: Modular Specification of Process Algebras
- 342/29/90 A Rob van Glabbeek, Peter Weijland: Branching Time and Abstraction in Bisimulation Semantics
- 342/30/90 A Michael Griebel: Parallel Multigrid Methods on Sparse Grids
- 342/31/90 A Rolf Niedermeier, Peter Rossmanith: Unambiguous Simulations of Auxiliary Pushdown Automata and Circuits
- 342/32/90 A Inga Niepel, Peter Rossmanith: Uniform Circuits and Exclusive Read PRAMs
- 342/33/90 A Dr. Hermann Hellwagner: A Survey of Virtually Shared Memory Schemes
- 342/1/91 A Walter Vogler: Is Partial Order Semantics Necessary for Action Refinement?
- 342/2/91 A Manfred Broy, Frank Dederichs, Claus Dendorfer, Rainer Weber: Characterizing the Behaviour of Reactive Systems by Trace Sets
- 342/3/91 A Ulrich Furbach, Christian Suttner, Bertram Fronhöfer: Massively Parallel Inference Systems
- 342/4/91 A Rudolf Bayer: Non-deterministic Computing, Transactions and Recursive Atomicity
- 342/5/91 A Robert Gold: Dataflow semantics for Petri nets
- 342/6/91 A A. Heise; C. Dimitrovici: Transformation und Komposition von P/T-Netzen unter Erhaltung wesentlicher Eigenschaften
- 342/7/91 A Walter Vogler: Asynchronous Communication of Petri Nets and the Refinement of Transitions

Reihe A

- 342/8/91 A Walter Vogler: Generalized OM-Bisimulation
- 342/9/91 A Christoph Zenger, Klaus Hallatschek: Fouriertransformation auf dünnen Gittern mit hierarchischen Basen
- 342/10/91 A Erwin Loibl, Hans Obermaier, Markus Pawlowski: Towards Parallelism in a Relational Database System
- 342/11/91 A Michael Werner: Implementierung von Algorithmen zur Kompaktifizierung von Programmen für VLIW-Architekturen
- 342/12/91 A Reiner Müller: Implementierung von Algorithmen zur Optimierung von Schleifen mit Hilfe von Software-Pipelining Techniken
- 342/13/91 A Sally Baker, Hans-Jörg Beier, Thomas Bemmerl, Arndt Bode, Hubert Ertl, Udo Graf, Olav Hansen, Josef Haunerding, Paul Hofstetter, Rainer Knödlseher, Jaroslav Kremenek, Siegfried Langenbuch, Robert Lindhof, Thomas Ludwig, Peter Luksch, Roy Milner, Bernhard Ries, Thomas Treml: TOPSYS - Tools for Parallel Systems (Artikelsammlung); 2., erweiterte Auflage
- 342/14/91 A Michael Griebel: The combination technique for the sparse grid solution of PDE's on multiprocessor machines
- 342/15/91 A Thomas F. Gritzner, Manfred Broy: A Link Between Process Algebras and Abstract Relation Algebras?
- 342/16/91 A Thomas Bemmerl, Arndt Bode, Peter Braun, Olav Hansen, Thomas Treml, Roland Wismüller: The Design and Implementation of TOPSYS
- 342/17/91 A Ulrich Furbach: Answers for disjunctive logic programs
- 342/18/91 A Ulrich Furbach: Splitting as a source of parallelism in disjunctive logic programs
- 342/19/91 A Gerhard W. Zumbusch: Adaptive parallele Multilevel-Methoden zur Lösung elliptischer Randwertprobleme
- 342/20/91 A M. Jobmann, J. Schumann: Modelling and Performance Analysis of a Parallel Theorem Prover
- 342/21/91 A Hans-Joachim Bungartz: An Adaptive Poisson Solver Using Hierarchical Bases and Sparse Grids
- 342/22/91 A Wolfgang Ertel, Theodor Gemenis, Johann M. Ph. Schumann, Christian B. Suttner, Rainer Weber, Zongyan Qiu: Formalisms and Languages for Specifying Parallel Inference Systems
- 342/23/91 A Astrid Kiehn: Local and Global Causes
- 342/24/91 A Johann M.Ph. Schumann: Parallelization of Inference Systems by using an Abstract Machine
- 342/25/91 A Eike Jessen: Speedup Analysis by Hierarchical Load Decomposition
- 342/26/91 A Thomas F. Gritzner: A Simple Toy Example of a Distributed System: On the Design of a Connecting Switch
- 342/27/91 A Thomas Schnekenburger, Andreas Weininger, Michael Friedrich: Introduction to the Parallel and Distributed Programming Language ParMod-C

Reihe A

- 342/28/91 A Claus Dendorfer: Funktionale Modellierung eines Postsystems
- 342/29/91 A Michael Griebel: Multilevel algorithms considered as iterative methods on indefinite systems
- 342/30/91 A W. Reisig: Parallel Composition of Liveness
- 342/31/91 A Thomas Bemmerl, Christian Kasperbauer, Martin Mairandres, Bernhard Ries: Programming Tools for Distributed Multiprocessor Computing Environments
- 342/32/91 A Frank Leßke: On constructive specifications of abstract data types using temporal logic
- 342/1/92 A L. Kanal, C.B. Suttner (Editors): Informal Proceedings of the Workshop on Parallel Processing for AI
- 342/2/92 A Manfred Broy, Frank Dederichs, Claus Dendorfer, Max Fuchs, Thomas F. Gritzner, Rainer Weber: The Design of Distributed Systems - An Introduction to FOCUS
- 342/2-2/92 A Manfred Broy, Frank Dederichs, Claus Dendorfer, Max Fuchs, Thomas F. Gritzner, Rainer Weber: The Design of Distributed Systems - An Introduction to FOCUS - Revised Version (erschienen im Januar 1993)
- 342/3/92 A Manfred Broy, Frank Dederichs, Claus Dendorfer, Max Fuchs, Thomas F. Gritzner, Rainer Weber: Summary of Case Studies in FOCUS - a Design Method for Distributed Systems
- 342/4/92 A Claus Dendorfer, Rainer Weber: Development and Implementation of a Communication Protocol - An Exercise in FOCUS
- 342/5/92 A Michael Friedrich: Sprachmittel und Werkzeuge zur Unterstützung paralleler und verteilter Programmierung
- 342/6/92 A Thomas F. Gritzner: The Action Graph Model as a Link between Abstract Relation Algebras and Process-Algebraic Specifications
- 342/7/92 A Sergei Gorlatch: Parallel Program Development for a Recursive Numerical Algorithm: a Case Study
- 342/8/92 A Henning Spruth, Georg Sigl, Frank Johannes: Parallel Algorithms for Slicing Based Final Placement
- 342/9/92 A Herbert Bauer, Christian Sporrer, Thomas Krodell: On Distributed Logic Simulation Using Time Warp
- 342/10/92 A H. Bungartz, M. Griebel, U. Rude: Extrapolation, Combination and Sparse Grid Techniques for Elliptic Boundary Value Problems
- 342/11/92 A M. Griebel, W. Huber, U. Rude, T. Störckuhl: The Combination Technique for Parallel Sparse-Grid-Preconditioning and -Solution of PDEs on Multiprocessor Machines and Workstation Networks
- 342/12/92 A Rolf Niedermeier, Peter Rossmanith: Optimal Parallel Algorithms for Computing Recursively Defined Functions
- 342/13/92 A Rainer Weber: Eine Methodik für die formale Anforderungsspezifikation verteilter Systeme

Reihe A

- 342/14/92 A Michael Griebel: Grid- and point-oriented multilevel algorithms
- 342/15/92 A M. Griebel, C. Zenger, S. Zimmer: Improved multilevel algorithms for full and sparse grid problems
- 342/16/92 A J. Desel, D. Gomm, E. Kindler, B. Paech, R. Walter: Bausteine eines kompositionalen Beweiskalküls für netzmodellerte Systeme
- 342/17/92 A Frank Dederichs: Transformation verteilter Systeme: Von applikativen zu prozeduralen Darstellungen
- 342/18/92 A Andreas Listl, Markus Pawlowski: Parallel Cache Management of a RDBMS
- 342/19/92 A Erwin Loibl, Markus Pawlowski, Christian Roth: PART: A Parallel Relational Toolbox as Basis for the Optimization and Interpretation of Parallel Queries
- 342/20/92 A Jörg Desel, Wolfgang Reisig: The Synthesis Problem of Petri Nets
- 342/21/92 A Robert Balder, Christoph Zenger: The d-dimensional Helmholtz equation on sparse Grids
- 342/22/92 A Ilko Michler: Neuronale Netzwerk-Paradigmen zum Erlernen von Heuristiken
- 342/23/92 A Wolfgang Reisig: Elements of a Temporal Logic. Coping with Concurrency
- 342/24/92 A T. Störtkuhl, Chr. Zenger, S. Zimmer: An asymptotic solution for the singularity at the angular point of the lid driven cavity
- 342/25/92 A Ekkart Kindler: Invariants, Compositionality and Substitution
- 342/26/92 A Thomas Bonk, Ulrich Rude: Performance Analysis and Optimization of Numerically Intensive Programs
- 342/1/93 A M. Griebel, V. Thurner: The Efficient Solution of Fluid Dynamics Problems by the Combination Technique
- 342/2/93 A Ketil Stølen, Frank Dederichs, Rainer Weber: Assumption / Commitment Rules for Networks of Asynchronously Communicating Agents
- 342/3/93 A Thomas Schnekenburger: A Definition of Efficiency of Parallel Programs in Multi-Tasking Environments
- 342/4/93 A Hans-Joachim Bungartz, Michael Griebel, Dierk Röschke, Christoph Zenger: A Proof of Convergence for the Combination Technique for the Laplace Equation Using Tools of Symbolic Computation
- 342/5/93 A Manfred Kunde, Rolf Niedermeier, Peter Rossmanith: Faster Sorting and Routing on Grids with Diagonals
- 342/6/93 A Michael Griebel, Peter Oswald: Remarks on the Abstract Theory of Additive and Multiplicative Schwarz Algorithms
- 342/7/93 A Christian Sporrer, Herbert Bauer: Corolla Partitioning for Distributed Logic Simulation of VLSI Circuits
- 342/8/93 A Herbert Bauer, Christian Sporrer: Reducing Rollback Overhead in Time-Warp Based Distributed Simulation with Optimized Incremental State Saving

Reihe A

- 342/9/93 A Peter Slavkovsky: The Visibility Problem for Single-Valued Surface ($z = f(x,y)$): The Analysis and the Parallelization of Algorithms
- 342/10/93 A Ulrich Rde: Multilevel, Extrapolation, and Sparse Grid Methods
- 342/11/93 A Hans Regler, Ulrich Rde: Layout Optimization with Algebraic Multigrid Methods
- 342/12/93 A Dieter Barnard, Angelika Mader: Model Checking for the Modal Mu-Calculus using Gau Elimination
- 342/13/93 A Christoph Pflaum, Ulrich Rde: Gau' Adaptive Relaxation for the Multilevel Solution of Partial Differential Equations on Sparse Grids
- 342/14/93 A Christoph Pflaum: Convergence of the Combination Technique for the Finite Element Solution of Poisson's Equation
- 342/15/93 A Michael Luby, Wolfgang Ertel: Optimal Parallelization of Las Vegas Algorithms
- 342/16/93 A Hans-Joachim Bungartz, Michael Griebel, Dierk Rschke, Christoph Zenger: Pointwise Convergence of the Combination Technique for Laplace's Equation
- 342/17/93 A Georg Stellner, Matthias Schumann, Stefan Lamberts, Thomas Ludwig, Arndt Bode, Martin Kiehl und Rainer Mehlhorn: Developing Multicomputer Applications on Networks of Workstations Using NXLib
- 342/18/93 A Max Fuchs, Ketil Stlen: Development of a Distributed Min/Max Component
- 342/19/93 A Johann K. Obermaier: Recovery and Transaction Management in Write-optimized Database Systems
- 342/20/93 A Sergej Gorlatch: Deriving Efficient Parallel Programs by Systematizing Coarsing Specification Parallelism
- 342/01/94 A Reiner Httl, Michael Schneider: Parallel Adaptive Numerical Simulation
- 342/02/94 A Henning Spruth, Frank Johannes: Parallel Routing of VLSI Circuits Based on Net Independency
- 342/03/94 A Henning Spruth, Frank Johannes, Kurt Antreich: PHIRoute: A Parallel Hierarchical Sea-of-Gates Router
- 342/04/94 A Martin Kiehl, Rainer Mehlhorn, Matthias Schumann: Parallel Multiple Shooting for Optimal Control Problems Under NX/2
- 342/05/94 A Christian Suttner, Christoph Goller, Peter Krauss, Klaus-Jrn Lange, Ludwig Thomas, Thomas Schnekenburger: Heuristic Optimization of Parallel Computations
- 342/06/94 A Andreas Listl: Using Subpages for Cache Coherency Control in Parallel Database Systems
- 342/07/94 A Manfred Broy, Ketil Stlen: Specification and Refinement of Finite Dataflow Networks - a Relational Approach

Reihe A

- 342/08/94 A Katharina Spies: Funktionale Spezifikation eines Kommunikationsprotokolls
- 342/09/94 A Peter A. Krauss: Applying a New Search Space Partitioning Method to Parallel Test Generation for Sequential Circuits
- 342/10/94 A Manfred Broy: A Functional Rephrasing of the Assumption/Commitment Specification Style
- 342/11/94 A Eckhardt Holz, Ketil Stølen: An Attempt to Embed a Restricted Version of SDL as a Target Language in Focus
- 342/12/94 A Christoph Pflaum: A Multi-Level-Algorithm for the Finite-Element-Solution of General Second Order Elliptic Differential Equations on Adaptive Sparse Grids
- 342/13/94 A Manfred Broy, Max Fuchs, Thomas F. Gritzner, Bernhard Schätz, Katharina Spies, Ketil Stølen: Summary of Case Studies in FOCUS - a Design Method for Distributed Systems
- 342/14/94 A Maximilian Fuchs: Technologieabhängigkeit von Spezifikationen digitaler Hardware
- 342/15/94 A M. Griebel, P. Oswald: Tensor Product Type Subspace Splittings And Multilevel Iterative Methods For Anisotropic Problems
- 342/16/94 A Gheorghe Ștefănescu: Algebra of Flownomials
- 342/17/94 A Ketil Stølen: A Refinement Relation Supporting the Transition from Unbounded to Bounded Communication Buffers
- 342/18/94 A Michael Griebel, Tilman Neuhoeffer: A Domain-Oriented Multilevel Algorithm-Implementation and Parallelization
- 342/19/94 A Michael Griebel, Walter Huber: Turbulence Simulation on Sparse Grids Using the Combination Method
- 342/20/94 A Johann Schumann: Using the Theorem Prover SETHEO for verifying the development of a Communication Protocol in FOCUS - A Case Study -
- 342/01/95 A Hans-Joachim Bungartz: Higher Order Finite Elements on Sparse Grids
- 342/02/95 A Tao Zhang, Seonglim Kang, Lester R. Lipsky: The Performance of Parallel Computers: Order Statistics and Amdahl's Law
- 342/03/95 A Lester R. Lipsky, Appie van de Liefvoort: Transformation of the Kronecker Product of Identical Servers to a Reduced Product Space
- 342/04/95 A Pierre Fiorini, Lester R. Lipsky, Wen-Jung Hsin, Appie van de Liefvoort: Auto-Correlation of Lag-k For Customers Departing From Semi-Markov Processes
- 342/05/95 A Sascha Hilgenfeldt, Robert Balder, Christoph Zenger: Sparse Grids: Applications to Multi-dimensional Schrödinger Problems
- 342/06/95 A Maximilian Fuchs: Formal Design of a Model-N Counter
- 342/07/95 A Hans-Joachim Bungartz, Stefan Schulte: Coupled Problems in Microsystem Technology

Reihe A

- 342/08/95 A Alexander Pfaffinger: Parallel Communication on Workstation Networks with Complex Topologies
- 342/09/95 A Ketil Stølen: Assumption/Commitment Rules for Data-flow Networks - with an Emphasis on Completeness
- 342/10/95 A Ketil Stølen, Max Fuchs: A Formal Method for Hardware/Software Co-Design
- 342/11/95 A Thomas Schnekenburger: The ALDY Load Distribution System
- 342/12/95 A Javier Esparza, Stefan Römer, Walter Vogler: An Improvement of McMillan's Unfolding Algorithm
- 342/13/95 A Stephan Melzer, Javier Esparza: Checking System Properties via Integer Programming
- 342/14/95 A Radu Grosu, Ketil Stølen: A Denotational Model for Mobile Point-to-Point Dataflow Networks
- 342/15/95 A Andrei Kovalyov, Javier Esparza: A Polynomial Algorithm to Compute the Concurrency Relation of Free-Choice Signal Transition Graphs
- 342/16/95 A Bernhard Schätz, Katharina Spies: Formale Syntax zur logischen Kernsprache der Focus-Entwicklungsmethodik
- 342/17/95 A Georg Stellner: Using CoCheck on a Network of Workstations
- 342/18/95 A Arndt Bode, Thomas Ludwig, Vaidy Sunderam, Roland Wismüller: Workshop on PVM, MPI, Tools and Applications
- 342/19/95 A Thomas Schnekenburger: Integration of Load Distribution into ParMod-C
- 342/20/95 A Ketil Stølen: Refinement Principles Supporting the Transition from Asynchronous to Synchronous Communication
- 342/21/95 A Andreas Listl, Giannis Bozas: Performance Gains Using Subpages for Cache Coherency Control
- 342/22/95 A Volker Heun, Ernst W. Mayr: Embedding Graphs with Bounded Treewidth into Optimal Hypercubes
- 342/23/95 A Petr Jančar, Javier Esparza: Deciding Finiteness of Petri Nets up to Bisimulation

SFB 342 : Methoden und Werkzeuge für die Nutzung paralleler
Rechnerarchitekturen

Reihe B

- 342/1/90 B Wolfgang Reisig: Petri Nets and Algebraic Specifications
342/2/90 B Jörg Desel: On Abstraction of Nets
342/3/90 B Jörg Desel: Reduction and Design of Well-behaved Free-choice
Systems
342/4/90 B Franz Abstreiter, Michael Friedrich, Hans-Jürgen Plewan: Das
Werkzeug runtime zur Beobachtung verteilter und paralleler
Programme
342/1/91 B Barbara Paechl: Concurrency as a Modality
342/2/91 B Birgit Kandler, Markus Pawlowski: SAM: Eine Sortier- Toolbox
-Anwenderbeschreibung
342/3/91 B Erwin Loibl, Hans Obermaier, Markus Pawlowski: 2. Workshop
über Parallelisierung von Datenbanksystemen
342/4/91 B Werner Pohlmann: A Limitation of Distributed Simulation
Methods
342/5/91 B Dominik Gomm, Ekkart Kindler: A Weakly Coherent Virtually
Shared Memory Scheme: Formal Specification and Analysis
342/6/91 B Dominik Gomm, Ekkart Kindler: Causality Based Specification and
Correctness Proof of a Virtually Shared Memory Scheme
342/7/91 B W. Reisig: Concurrent Temporal Logic
342/1/92 B Malte Grosse, Christian B. Suttner: A Parallel Algorithm for Set-
of-Support
Christian B. Suttner: Parallel Computation of Multiple Sets-of-
Support
342/2/92 B Arndt Bode, Hartmut Wedekind: Parallelrechner: Theorie, Hard-
ware, Software, Anwendungen
342/1/93 B Max Fuchs: Funktionale Spezifikation einer Geschwindigkeits-
regelung
342/2/93 B Ekkart Kindler: Sicherheits- und Lebendigkeitseigenschaften: Ein
Literaturüberblick
342/1/94 B Andreas Listl; Thomas Schnekenburger; Michael Friedrich: Zum
Entwurf eines Prototypen für MIDAS